

SHIFTIN' BOBBINS



SOCIAL GROUP

TORONTO

5TH ANNUAL ST. ANDREW'S CELEBRATION DANCE

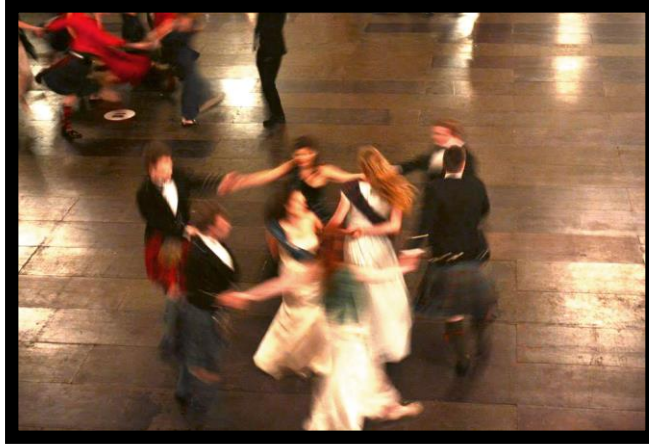

SATURDAY NOVEMBER 24, 2018

GRACE CHURCH-ON THE HILL  
300 LONSDALE ROAD TORONTO M4V 1X4

8.00 PM TO 10.00 PM FOLLOWED BY FINGER FOOD BUFFET

MUSIC BY "SCOTCH MIST"

---

PROGRAMME

*The Machine Without Horses (J)*

*Catch the Wind (J)*

*The Clansman (R)*

*The Earl of Mansfield (R)*

*Ladies of Berkeau (S)*

*The Flower of Glasgow (S)*

*Fugal Fergus (J)*

*Napier's Index (J)*

*Lord MacLay's Reel (R)*

*Ramadan-ce (R)*

*The Glasgow Highlanders (S)*

*Anne Mcarthur (S)*

*Best Set in the Hall (J)*

*Mairi's Wedding (R)*

**DANCES WILL BE RECAPPED ONLY, NOT WALKED**

# Shiftn'Bobbins Nov 24/18



## 1 THE MACHINE WITHOUT HORSES J32 · 3/4L

David Rutherford: RSCDS XII 12 · Crib: MiniCribbs · Diagram: Keith Rose's Diagrams

- 1-8 1s set, cast & dance RH across with 3s
- 9-16 1s set, cast up & dance LH across with 2s
- 17-24 1s followed by 2s dance down, cast up behind 3s, in & dance up to top & 1s cast back to 2nd place
- 25-32 2s+1s dance R&L

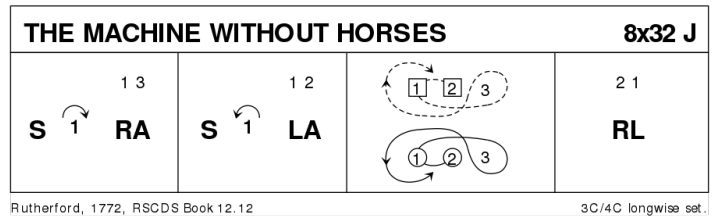

## 2 THE CLANSMAN R32 · 2/4L

Derek Haynes: RSCDS XXXII 8 · Crib: MiniCribbs · Diagram: Keith Rose's Diagrams

- 1-8 1s cross RH & cast down 1 place, 2s+1s dance 1/2 RH across & set
- 9-16 1s+2s dance R&L, ending with Men turning Ladies into centre to form a line across
- 17-24 1s+2s dance the Targe :
  - 17-18 1st & 2nd Ladies 3/4 turn RH while Men dance 1/4 way round anticlockwise
  - 19-20 1st Man with 2nd Lady & 1st Lady with 2nd Man full turn LH
  - 21-22 1st & 2nd Ladies 3/4 turn RH while Men dance 1/4 way round anticlockwise
  - 23-24 1st Man with 2nd Lady & 1st Lady with 2nd Man turn LH to end on sides 1s facing up & 2s facing down
- 25-32 2s+1s set facing on sides, turn to face partners & set, 1s lead up crossing RH & cast to 2nd place on own sides

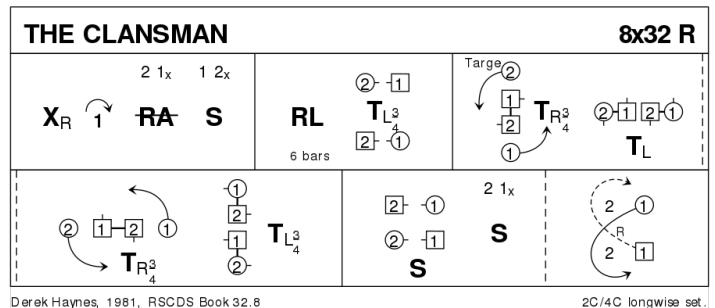

## 3 LADIES OF BERKEAU S32 · 3/4L

Jon Allen-Friend: Six original Scottish country dances · Crib: MiniCribbs · Diagram: Keith Rose's Diagrams

- 1-8 1s+2s+3s set & 1/2 turn 2H to opposite sides, repeat back to own sides
- 9-16 1s cross down & dance reflection reels of 3 on opposite sides ending in partner's place
- 17-24 1s dance down for 2 bars & Lady turns under Mans R arm, turn 2H & dance up to places
- 25-32 1s+2s dance the Knot:
  - 25/26 Couples turn ptrns RH 1/2 way to end in the centre facing down in Allemande position, the Lady having turned clockwise under her ptrns arm
  - 27/28 Bottom couple followed by the others dance up on Ladies' side
  - 29/32 Couples turn partners (slowly) by LH to own sides

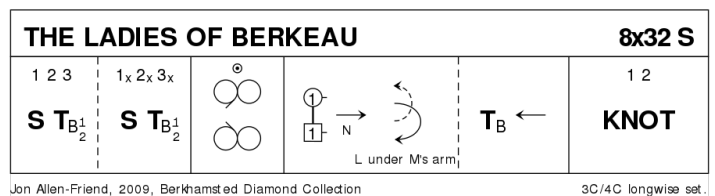

## 4 FUGAL FERGUS J48 · 3/4L

Hugh Foss: Magazine Dances 2005-2009 · Crib: MiniCribbs · Diagram: Keith Rose's Diagrams

Fugue dance - Men copy Ladies 8 bars later

- 1-8** 1L followed by 2L+3L dance anticlockwise round 1+2+3M & back up to places (Men stand)
- 9-16** 1L+2L+3L set & cross, set & cross back (Men repeat Ladies Figs but 8 bars behind)
- 17-24** 1L+2L+3L set & cross RH, turn to right & 1L followed by 2L+3L dance clockwise & down own side (Men Ditto)
- 25-32** 1L+2L+3L dance reel of 3 on own side (1L RSh to 2L to start) (Men Ditto)
- 33-40** 1L+2L+3L dance 1/2 reel of 3 on own side, 1L+2L turn LH 1.1/2 times on side to change places (Ditto but 1M & 2M pass LSh)
- 41-48** All Ladies stand **while** Men complete last Fig (Men Ditto & end 1M+2M turning RH)

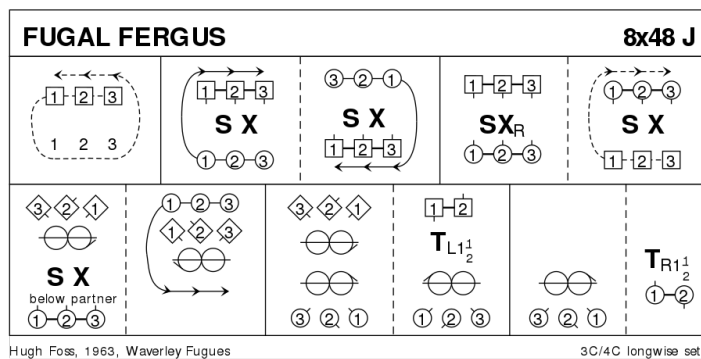

## 5 THE GLASGOW HIGHLANDERS S32 · 2/4L

Walter F Gillies: RSCDS II 3 · Crib: MiniCribbs · Diagram: Keith Rose's Diagrams

2 Ch - 1M stand as 1L crosses to 2M pl who crosses to ptnrs pl, 2L steps up

- 1-8** 1s+2s dance R&L ending with 2M between 1L+2L facing down 1M directly behind 2M
- 9-16** All dance down middle, turn right about & 1M dances Ladies back to top (2M follows) to form a line 4 across with Men BtoB facing partners
- 17-24** All set to partners with suitable step
- 25-32** All dance reel of 4 across ending in new ptns with each couple having moved 1 place anticlockwise round set  
On bars 31/32 3M crosses to partners place as 3L steps up to start next 32 bars  
Similarly on bars 31/32 (2nd time through) 4M crosses to partners places as 4L steps up

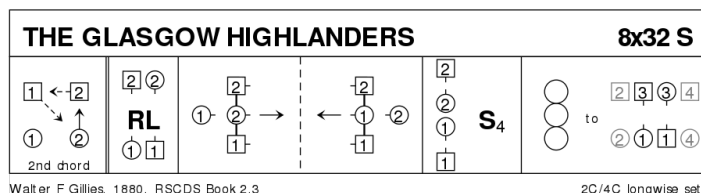

## 6 CATCH THE WIND R32 · 3/4L

Romaine Butterfield: RSCDS XLV 5 · Crib: MiniCribbs · Diagram: Keith Rose's Diagrams

- 1-8** 1s set, cast 1 place & dance 1/2 Fig of 8 round 2s
- 9-16** 1s set twice with 1L turning to face out, 1L followed by partner casts up & dances down the middle 1L to face 3M **while** 1M faces 2M
- 17-24** 1s RSh reels of 3 across (1M with 2s & 1L with 3s)
- 25-32** 1L followed by partner dances down cast up round 3M & crosses to end in 2nd place on own sides, 1s turn RH (4 bars)

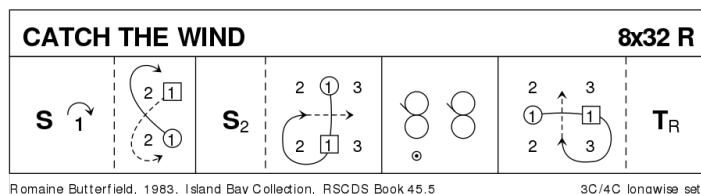

## 7 BEST SET IN THE HALL J32 · 3/4L

Helen Greenwood: RSCDS XLVI 7 · Crib: MiniCribbs · Diagram: Keith Rose's Diagrams

- 1-8** 1s set & 1L followed by partner casts below 3s. 1L crosses & casts up to face her 1st corner **while** 1M dances up the middle to face 1st corner
- 9-12** 1s set to 1st corners & dance RSh round each other into 3rd corner (pstn) **while** 1st corners dance in & turn right about to face their original position
- 13-16** 1s+1st crnr person set & 1st crnr persons dance RSh round each other into diag opp cnrns **while** 1s dance in & pivot to right to face 2nd cnrns
- 17-24** 1s repeat bars 9-16 with 2nd corners & end passing RSh to 2nd place opposite sides. (3)(1)(2)
- 25-32** 2s+1s+3s chase clockwise 1/2 way & turn partners RH

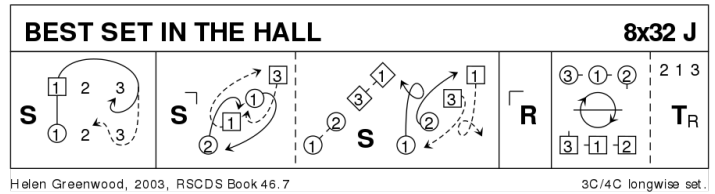

## 8 THE EARL OF MANSFIELD R48 · 4/4L

John Drewry: The Leaflet Dances with Music · Crib: MiniCribbs · Diagram: Keith Rose's Diagrams

- 1-8** 1s+2s circle 4H round & back
- 9-16** 1s+2s also 3s+4s face on sides, all set & change places RH, all set & change back RH
- 17-24** 1M reel of 3 with 2s (LSh to 2L) picking up partner in prom hold to complete reel as 3M dances similarly with 4s, 1s+3s end on Men's side
- 25-32** 3s followed by 1s dance down below 4s, 3s cast, in & lead up to top, cross & cast back to place **while** 1s cast up & turn LH to face 1st cnrns
- 33-40** 1s turn 1st corners RH pass partner RSh, turn 2nd corner LH, pass LSh to end 2nd place in centre facing up
- 41-48** 1L+2L+3L dance RH across (on side) as 1M+2M+3M LH across, 1s followed by 3s dance down to 4s & Ladies dance LH across as Men RH across to end 2 3 4 1

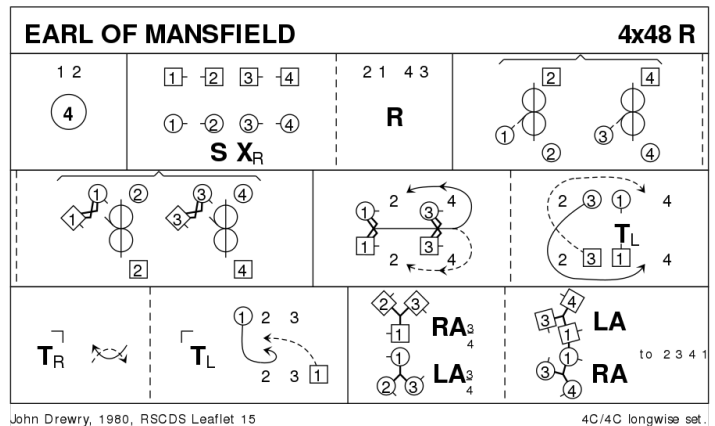

## 9 THE FLOWER OF GLASGOW S32 · 3/3L

Ruth Taylor (CAN): RSCDS XLVI 9 · Crib: MiniCribbs · Diagram: Keith Rose's Diagrams

- 1-8** 1L followed by partner casts 2 places, 1L crosses & casts up on Men's side to 2nd place **while** 1M dances up the middle to 2nd place Ladies' side. All set advancing into prom hold (2s & 3s face up, 1s down) 2(1)3
- 9-16** 2s+1s+3s dance "Circulating Allemande":  
2s & 3s dance normal Allemande but end in 3rd/1st place as 1s Allemande (down) & up to 2nd place opposite sides. 3(1)2
- 17-24** 1s dance 1/2 Figs of 8 (1L up round 3s, 1M down round 2s), all turn partners 2H. 3 1 2
- 25-32** 1s+2s dance Diamond poussette

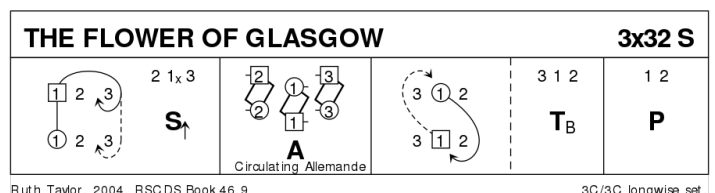

## 10 NAPIER'S INDEX J40 · 3/4L

Brian Charlton: RSCDS XLV 8 · Crib: MiniCribbs · Diagram: Keith Rose's Diagrams

- 1-8** 1s set & cast 1 place, turn LH 1.1/4 times to end in Bal-in-Line position between 1st corners
- 9-16** 1s+1st corners Bal-in-Line & turn corners RH (4 bars) to Bal-in-Line again with 1st corners
- 17-24** 1s dance reel of 3 on sides (LSh to 2nd corner) & end diagonally between 2nd corners
- 25-32** 1s+2nd corners Bal-in-Line & turn corners RH (4 bars), Bal-in-Line again with 2nd corners
- 33-40** 1s dance reels of 3 across (LSh to 3rd corners) & cross RH to 2nd places

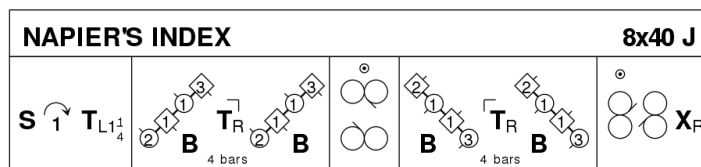

Brian Charlton, 2001, RSCDS Book 45.8

3C/4C longwise set.

## 11 RAMADAN-CE R32 · 3/4L

John Drewry: The Turkish Set · Crib: MiniCribbs · Diagram: Keith Rose's Diagrams

- 1-8** 1s dance Inveran Reels with 2s+3s
- 9-16** 1s cross RH, cast 1 place & turn RH to face 1st corners
- 17-24** 1s dance RSh round 1st corner, pass RSh & dance RSh round 2nd corner to end 2nd place opposite side **while** 1st corners dance in, 1/2 turn RH, twirl & dance out to each others place, 2nd corners dance similarly. (3)(1)(2)
- 25-32** 1s dance 1/2 LSh reels of 3 across (Man at top with 3s & Lady at bottom with 2s), 1s dance 1/2 RSh reels of 3 on own sides (Man Down, Lady up)

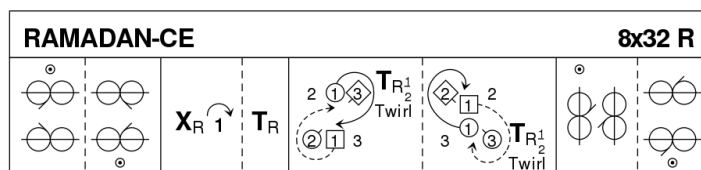

John Drewry, 2000, Turkish Set

3C/4C longwise set.

## 12 ANNE MCARTHUR S32 · 3/3L

Jim Stott: 9 for 90 RSCDS Aberdeen Branch 90th Anniversary 1 · Crib: MiniCribbs · Diagram: Keith Rose's Diagrams

- 1-8** 1s+2s+3s circle 6H round and back.
- 9-16** 1s set and cast off, 1s turn LH to face 1st corners.
- 17-24** 1s set and turn 1st corner, set and turn 2nd corner to finish in 2nd place opposite side.
- 25-28** 2s+1s+3s set. 1s cross RH to 2nd place own side.
- 29-32** 1s+3s set and link.

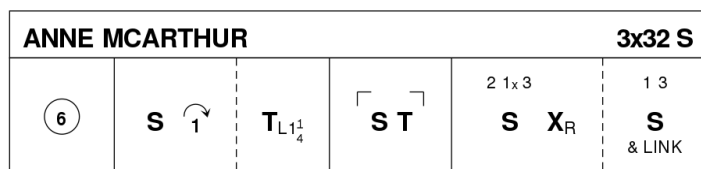

Jim Stott, 2006, 9 for 90 RSCDS Aberdeen Branch

3C/3C longwise set.

# 13 MAIRI'S WEDDING R40 · 3/4L

James B Cosh: *Twenty Two SCD · Crib: MiniCribs · Diagram: Keith Rose's Diagrams*

- 1-8** 1s turn RH & cast to 2nd place, 1s turn LH to face 1st corners
- 9-16** 1s dance 1/2 diagonal reel of 4 with 1st corners, 1s dance 1/2 diagonal reel with 2nd corners
- 17-24** 1s dance 1/2 diagonal reel with 3rd corner (pstns), 1/2 diagonal reel with 4th corner (pstns)
- 25-32** 1s dance reel of 3 across (Lady with 2s, Man with 3s - LSh to 1st corner)
- 33-40** 2s+1s+3s circle 6H round & back

