

# V December SCD Weekend in Portugal

Curia, Portugal

1 December 2018

## Gala Ball

Music: Keith Smith (fiddle) & Peter Shand (piano)

1. Festival Interceltique	R40	Ian Brockbank
2. The White Heather Jig	4x40J	James B. Cosh 22 SCDs
3. Sandy's Scotch Broth	3x32S	Gail Sibley Katannuta Book
4. Dancing Dolphins	8x32J	Barry Skelton Dolphin Book
5. <b>TEACHER'S CHOICE</b>		
6. The Silver Tassie	8x32S	John Drewry Bon Accord Book
7. The Rainbow Fairy	J96	Isabel Neves Sintra Seminar 2018
8. The Falls of Rogie	8x32R	Jean Attwood Alexander Book 1

## Interval

9. Napier's Index	8x40J	Brian Charlton RSCDS Book 45
10. Out of Thin Air	3x32S	Sue Porter And Diane Rooney RSCDS Graded 3
11. The Black Mountain Reel	5x32R	Derek Haynes Carnforth Collection 3
12. Links with St Petersburg	8x32J	Malcolm Brown RSCDS Book 46
13. Up in the Air	8x32S	Boag RSCDS Book 20
14. Hungarian Bride	5x48R	Eric Finley, A Reel Goulash
15. Chased Lovers	8x32J	Tim Wilson World Wide Weavings 2015
16. Irish Rover	8x32R	James B. Cosh 22 SCDs

## Extras

17. Early Spring	3x32S	Isabel Neves IB 10th Anniversary
18. Reel of the 51 <sup>st</sup> Division	8x32R	Atkinson RSCDS Bk 13



**1) FESTIVAL INTERCELTIQUE (R40)** Round The Room Ian Brockbank  
Circle around the room with partner on Man's right

- 1- 8 All circle left and back
- 9-16 All couples with nearer hands raised as Ladies dance in front and round partner (Men stand still), Men dance in front and round partner
- 17-24 All in circle Adv+Ret twice
- 25-32 All turn partner RH, Men turn Lady on left LH into prom hold
- 33-40 All with new partners promenade round to reform circle with new partners

**Keith Rose's Crib Diagrams**

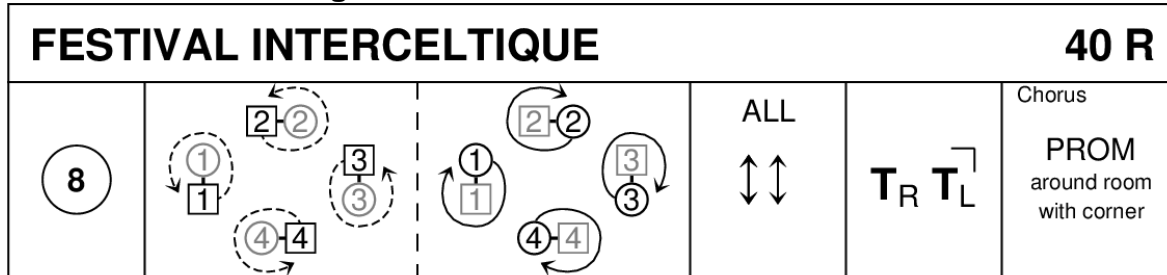

Ian Brockbank, RSCDS 4/2008

1C/1C progressive.

**2) THE WHITE HEATHER JIG (J4x40)** 4C set James B. Cosh 22 SCDs

- 1- 8 1s turn RH and cast to 2nd place, turn 1½ LH to end between 2s facing opposite sides
- 9-16 1s+2s dance reel of 4 across, 1s pass RSh to face 1st corners
- 17-24 1s turn corner, partner, corner, partner, to end between 3s facing opposite sides
- 25-32 1s+3s dance reel of 4 across, 1s end in middle between 3s and 4s
- 33-40 1s turn LH, cast to 4th place on own side and turn RH

**Keith Rose's Crib Diagrams**

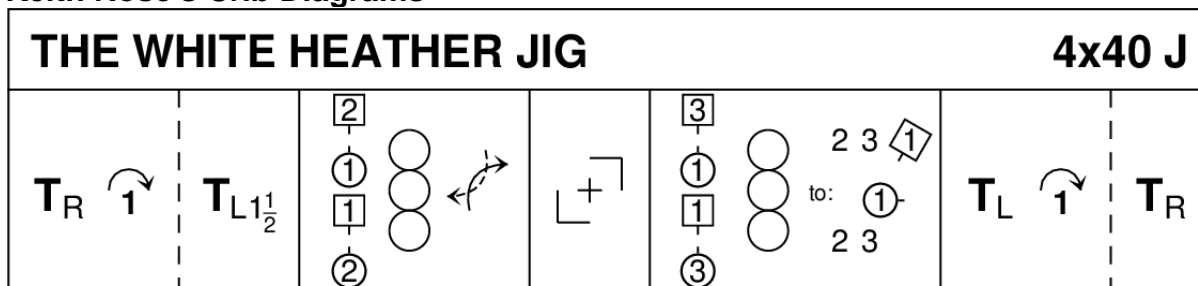

James Cosh, 22 SCD & 2 Others

4C/4C longwise set

**3) SANDY'S SCOTCH BROTH (S3x32)** 3C set Gail Sibley Katannuta Book

- 1- 8 All circle 6H round and back
- 9-16 1s dance down middle and set, dance up and cast to 2nd place ending facing 1st corners
- 17-24 1s dance Pass&Turn with 1st corners and pass RSh to face 2nd corners, dance Pass&Turn with 2nd corners to end 2nd place own sides
- 25-32 Promenade (Chaperoned) Chain progression:-
  - ' 25-26 2s and 3s ¾ turn partner RH into middle while 1s dance clockwise ¼ round the set picking up 2L/3M...
  - ' 27-30 who promenade ½ way clockwise while middle dancers (2M + 3L) turn LH 1½
  - ' 31-32 2s and 3s turn partner RH ¾ to own sides while 1s dance clockwise ¼ round to end in 2nd place. 312



## Keith Rose's Crib Diagrams

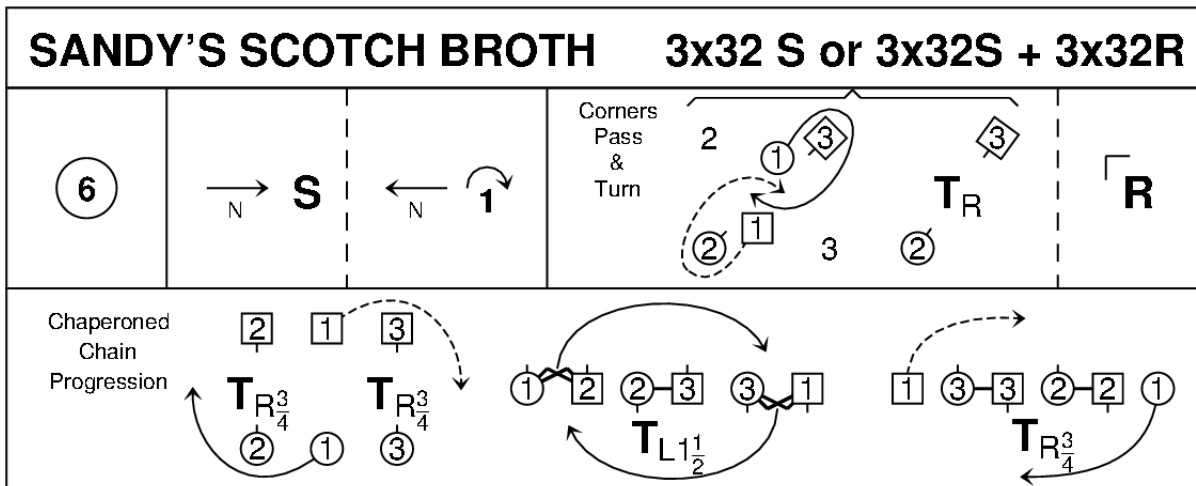

Gail Sibley, Katannuta Collection

3C/3C longwise set.

### 4) DANCING DOLPHINS (J8x32) 3C (4C set) Barry Skelton Dolphin Book

1- 8 1s cross RH, cast 1 place (2s step up). 1s turn LH  $1\frac{1}{4}$  times to end facing Ladies' side, 1L on 1M's right (\*see note)

9-16 1s dance Alternating Tandem reel of 3 on Ladies' side (1L leads starting RSh to 3L)

17-24 1s dance Alternating Tandem reel on Men's side (1L leads starting LSh to 3M) and end in prom hold facing Ladies' side

25-32 1s dance out between 2L+3L, cast round 3L and dance up to top of set, drop hands and cast to 2nd place own side

\*Note: 1s cover, remaining parallel to line of set throughout reels (bars 9-24)

## Keith Rose's Crib Diagrams

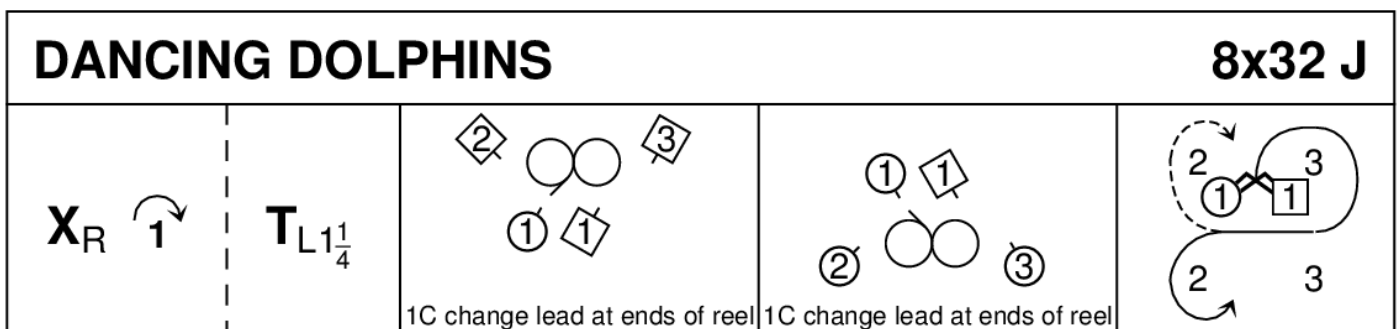

B Skelton, 1993, Dolphin Book

3C/4C longwise set.

### 5) TEACHER'S CHOICE

### 6) THE SILVER TASSIE (S8x32) 3C (4C set) John Drewry Bon Accord Book

8 1s+2s+3s cross RH and set, cross back RH and set

9-16 1s and 3s dance double Fig of 8 round 2s (3s casting)

17-24 1s followed by 2s+3s dance down, 1s followed by 2s+3s (who part to let 1s through) dance back to top

25-32 1s+2s dance the Rondel. 213



## Keith Rose's Crib Diagrams

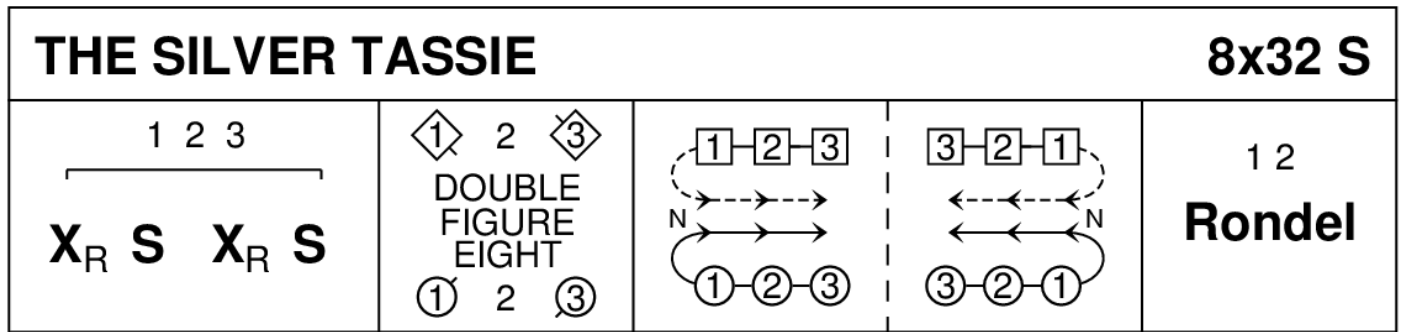

John Drewry, 1966, RSCDS Leaflet 1

3C/4C longwise set.

### 7) THE RAINBOW FAIRY (J 96) Sq. Set Isabel Neves Sintra Seminar 2018

1- 8 1M passes 1L in front, near hands joined, and they dance half figure of 8 on the sides, 1L round 2M and 1M round 4L, and face them, as 3M and 3L do the same round 2L/4M.

All set on the last 2 bars.

9-16 2s, making an arch, change places with 3M+1L, who dance under the arch, as 4s do the same with 3L+1M (bars 9-10); 2s cross Rh with 4s(1) as 3M/1M change places with 1L/3L, turning back and ladies dancing under men's arm (bars 11-12); repeat bars 9-12 from new positions (bars 13-16)

17-24 4s with 1M+3L and 2s with 1L+3M dance a circle to the left (bars 17-20), and open to dance a circle ½ way to the left, ending in a square set, 2s and 4s in the original positions, 3s and 1s having changed places (bars 21-24)

25-48 2s and 4s repeat bars 1-24.

49-56 3s and 1s dance ½ R&L; 4s and 2s dance ½ R&L.

57-64 Near hands joined with partner, all set advancing to give hands and form a circle(2) (bars 57-58); all set (bars 59-60), 4 spring points (bars 61-62) and set turning to their partner (bars 63-64).

65-72 All birl with their partners to end in the original square set, ladies facing their partners, men facing in.

73-80 Double men's chain (in the end ladies face out, men face in)

81-88+89-96 Full Schiehallion Reels (end facing partner)

Notes:

(1) Small steps for crossing with the Rh

(2) The widest possible circle

### 8) THE FALLS OF ROGIE (R8x32) 3C (4C set) Jean Attwood Alexander Book 1

1- 8 1s cross RH and cast 1 place, 1s cross RH and cast 1 place (Man up Lady down)

9-16 1s dance ½ reels of 3 across (1M with 2s and 1L with 3s), set in lines across and change places RH with opposite person

17-24 2s+1s+3s chase clockwise ½ way, 1s dance in and turn RH to face 1st corner pstns as 2s and 3s continue to chase on to places (as bar 16)

25-32 1s dance ½ reel of 4 with 1st corners, passing RSh dance ½ reel with 2nd corners and cross passing RSh to 2nd place own sides

## Keith Rose's Crib Diagrams



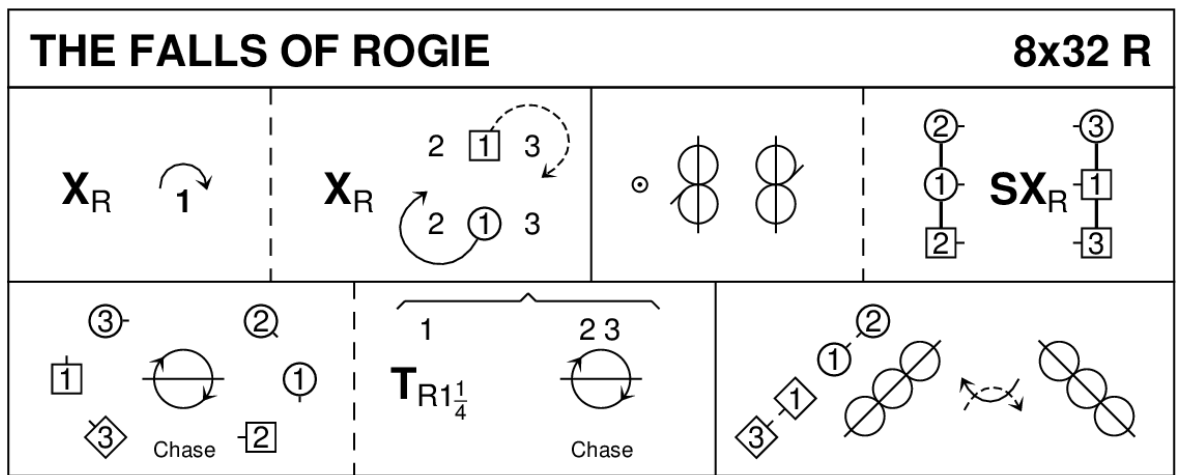

Jean Attwood, Alexander Dances 1

3C/4C longwise set

### INTERVAL

#### 9) NAPIER'S INDEX (J8x40) 3C (4C set) Brian Charlton RSCDS Book 45

- 1- 8 1s Set&Cast 1 place, turn LH 1¼ times to end in Balance-in-Line position between 1st corners
- 9-16 1s+1st corners Balance-in-Line and turn corners RH (4 bars) to Balance-in-Line again with 1st corners
- 17-24 1s dance reel of 3 on sides (LSh to 2nd corner) and end diagonally between 2nd corners
- 25-32 1s+2nd corners Balance-in-Line and turn corners RH (4 bars), Balance-in-Line again with 2nd corners
- 33-40 1s dance reels of 3 across (LSh to 3rd corners) and cross RH to 2nd places. 213

#### Keith Rose's Crib Diagrams

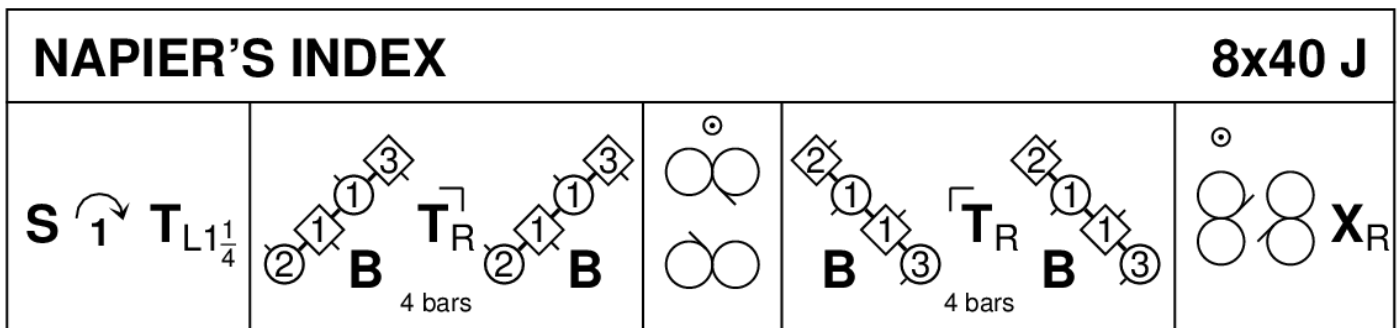

Brian Charlton, 2001, RSCDS Book 45.8

3C/4C longwise set.

#### 10) OUT OF THIN AIR (S3x32) 3C set Sue Porter And Diane Rooney RSCDS Graded 3

- 1- 8 1s set, cross RH, cast, turn LH to face 1st corners (2s step up bars 5-6)
- 9-16 1s turn corner RH, partner LH, 2nd corner RH, partner LH to finish in middle, own side, facing up
- 17-24 1s dance up between 2s, cast, dance down between 3s and cast up into 2nd place own sides
- 25-32 1s+3s dance the Tournée:-
- ' 1s+3s dance into prom hold (Men with partner on right, 1s face Men's side and 3s Ladies' side), couples ½ wheel anticlockwise and Men turn Ladies into middle, both couples turn 1½ times (3s RH, 1s LH) and dance out to places



**Keith Rose's Crib Diagrams**

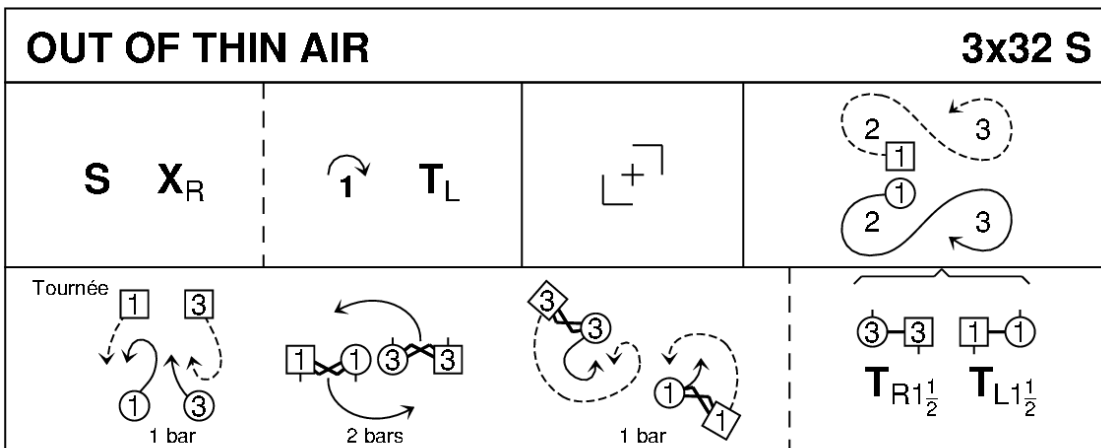

Sue Porter & Di Rooney, RSCDS Graded Book 3.13

3C/3C longwise set.

**11) THE BLACK MOUNTAIN REEL (R5x32) 5C set Derek Haynes Carnforth Collection 3**

1- 8 1s and 3s cross RH and cast down 1 place, dance 1/2 Fig of 8 round the couples above them and cross to face 1st corners

9-16 1s and 3s turn 1st corners RH and partner LH, turn 2nd corner RH and partner LH to face 1st corners again

17-24 1s and 3s dance diagonal reels of 4 with 1st corners

25-32 All dance RH across once round (1L with 2s, 1M+3L with 4s and 3M with 5s), 1s and 3s turn partners LH and cast one place. 24153

**Keith Rose's Crib Diagrams**

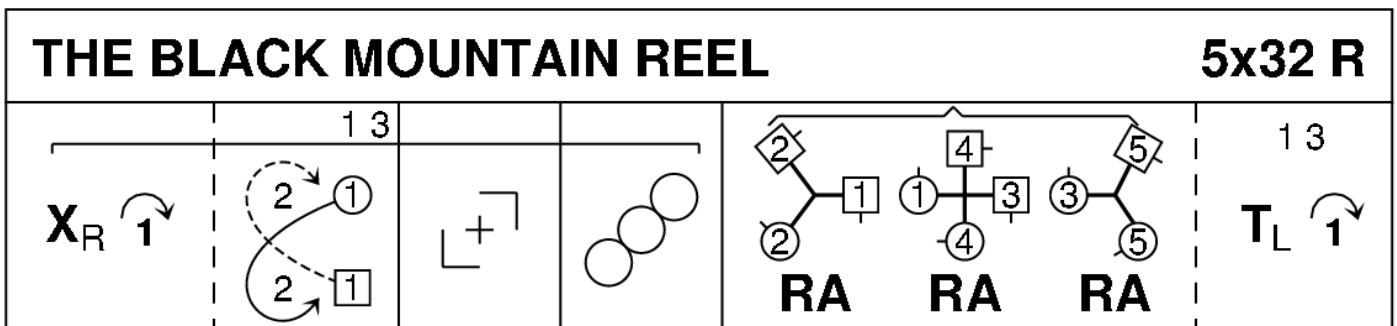

Derek Haynes, 1968, Carnforth Collection 3

5C/5C longwise set.

**12) LINKS WITH ST PETERSBURG (J8x32) 3C (4C set) Malcolm Brown RSCDS Book 46**

1- 8 1s+2s Set&Link ending 2s facing 1s nearer hands joined, 2s and 1s Set&Link with partners. (2)(1)3

9-16 1s followed by 2s dance down for 3 bars and change places with Lady dancing under Man's arm, 2s+1s dance up to 1st and 2nd places

17-24 2M+1M turn LH as 2L+1L turn RH, 1M+3M turn RH as 1L+3L turn LH and 1s end facing 1st corners

25-32 1s dance 'Hello-Goodbye' setting and petronella turn to 2nd place own sides

**Keith Rose's Crib Diagrams**



LINKS WITH ST PETERSBURG				8x32 J	
1 2 <b>S</b> & LINK	 <b>S</b> & LINK	2x 1x      2 1 →      ↺      ← N      L under M arm      N	 <b>T<sub>R</sub></b>	 <b>T<sub>L</sub></b>	 <b>S S S T<sub>◇</sub></b>

Malcolm Brown, 2009, RSCDS Book 46.10

3C/4C longwise set.

### 13) UP IN THE AIR (S8x32) 3C (4C set) Boag RSCDS Book 20

1- 8 1s cast down behind own lines, turning out cast back to top. Bar 8 all 3 couples dance in ready for...

9-16 1s+2s+3s Promenade, 1s cast and face 1st corners, 2s dance up to 1st place

17-24 1s set to 1st corners, set to 2nd corners, pull back RSh turning into 2nd place opposite sides, 2s+1s+3s circle 6H round to left

25-32 2s+1s+3s Adv&Ret and turn 2H 1s ending in 2nd place own sides

#### Keith Rose's Crib Diagrams

UP IN THE AIR				8x32 S	
 1 2 3 4 ① 2 3 4	1 2 3 <b>PROM</b> 1	 <b>S</b>	2 1x 3  <b>6</b>	 2 1x 3 ↑↓ ② ① ③	2 1x 3 <b>T<sub>B</sub></b> to own sides

Boag, 1797, RSCDS Book 20.2

3C/4C longwise set.

### 14) HUNGARIAN BRIDE (R5x48) 5C Eric Finley, A Reel Goulash

1- 8 1c+2c+3c+4c making arches advance to centre | set turning towards corner and join NH ; with cnr dance out making arch | set advancing to original places **while**{8} 5c dances through arch on the R (5M between 4c, 5W between 2c) | cast L to diagonal ; dance in through the arch to the centre | Gypsy Turn (pass Rsh, face P and 5M swivel R) to face 2c, 5M with 5W behind

9-16 4c+2c in promhold + 5c Rsh lead-change Reel3, finish 5c (5M leading) facing 1c

17-24 Repeat with 1c+3c, using Lsh, 5c finish in middle 5M leading

25-32 2c+5c RHA ; 5c+4c LHA, 5c finish facing 1c, 5W on R

33-40 5c (centre couple) NHJ dance under arch by 1c (outside couple) | 5c change places, 5W dancing under joined arms and 5M round behind, **while** {2} 1c Gypsy Turn to face 2c ; 1c+2c repeat, and 2c face 3c

41-48 2c+3c repeat; 3c+4c repeat, finish 4M above and facing 4W (5,1,2,3,4)

#### Keith Rose's Crib Diagrams



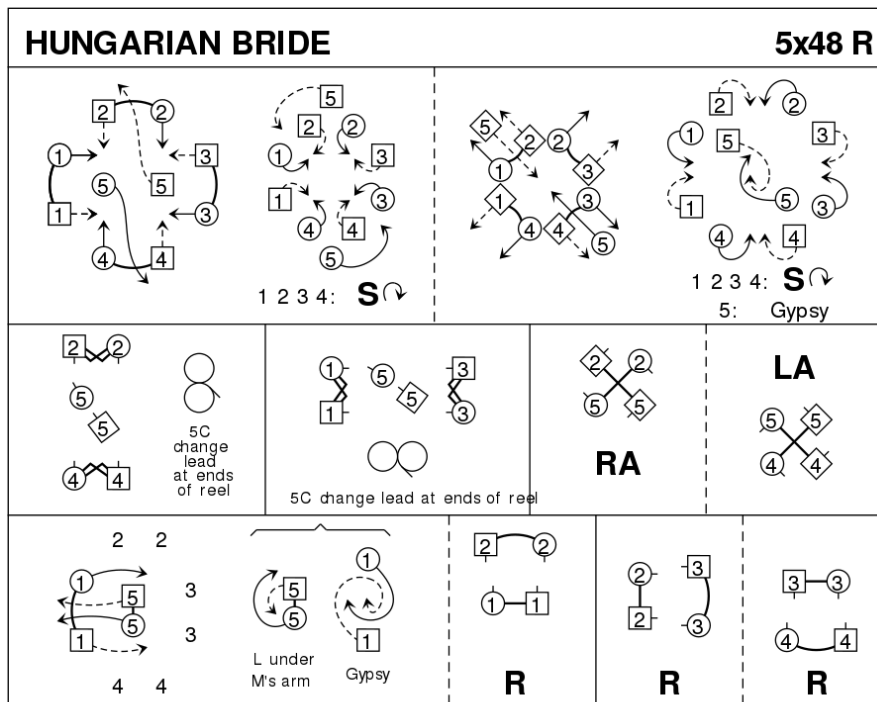

Eric Finley, 2007, A Reel Goulash

5C/5C square set.

### 15) CHASED LOVERS (J8x32) 3C (4C set) Tim Wilson World Wide Weavings 2015

- 1- 4 1s set, cross down (no hands) to 2nd place facing out (2s step up 3-4)
- 5- 8 1s cast down behind 3s, meet and dance up centre with 1L leading, 1M following, to face 2M (her 1st corner)
- 9-16 1s, in tandem, dance LSh reel of 3 on 1st corner diagonal (out of top of set to start), finishing by 1s pulling back RSh to face down, 1M leading, facing 3M
- 17-24 1s, in tandem, dance RSh reel of 3 on 2nd corner diagonal (out bottom of set to start), finishing with 1s facing own 1st corners
- 25-32 1s dance Pass&Turn with 1st corners, (pass RSh), Pass&Turn with 2nd corners, finishing passing RSh to 2nd place own sides

### Keith Rose's Crib Diagrams

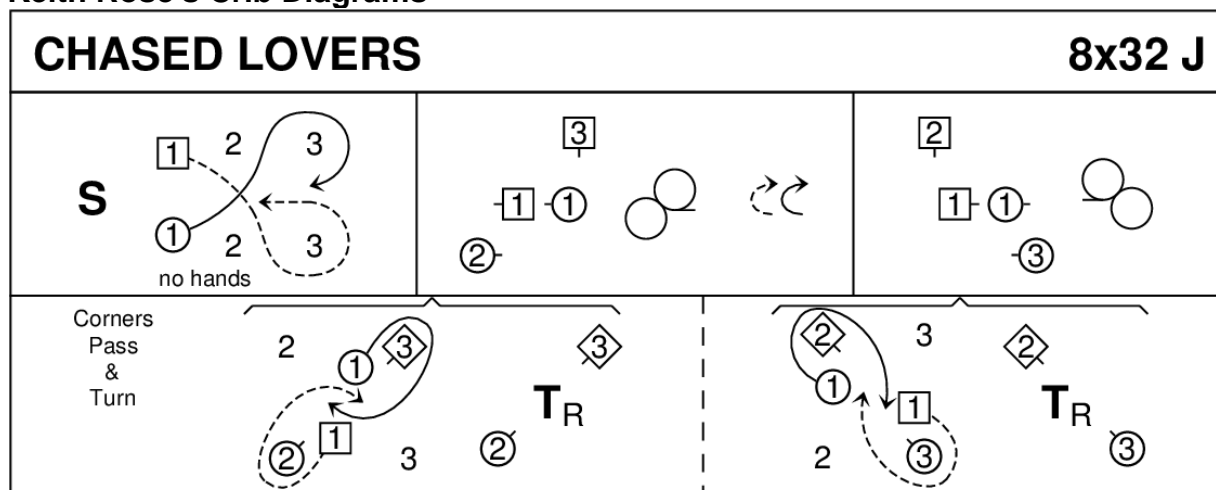

Tim Wilson, World Wide Weavings

3C/4C longwise set.





**16) IRISH ROVER (R8x32) 3C (4C set) James B. Cosh 22 SCDs**

1- 8 1s dance down below 3s and cast up to 2nd place own sides, 1L dances RH across with 2s while 1M dances RH across with 3s

9-16 1s dance 1/2 diagonal reel of 4 with 1st corners, 1/2 reel with 2nd corners and 1/2 turn LH in centre to face 1st corners

17-24 1s dance reels of 3 across giving LSh to 1st corners ending in 2nd place own sides. (3)1(2)

25-32 1s dance diagonal R&L (1M crossing down and 1L crossing up to start). 213

**Keith Rose's Crib Diagrams**

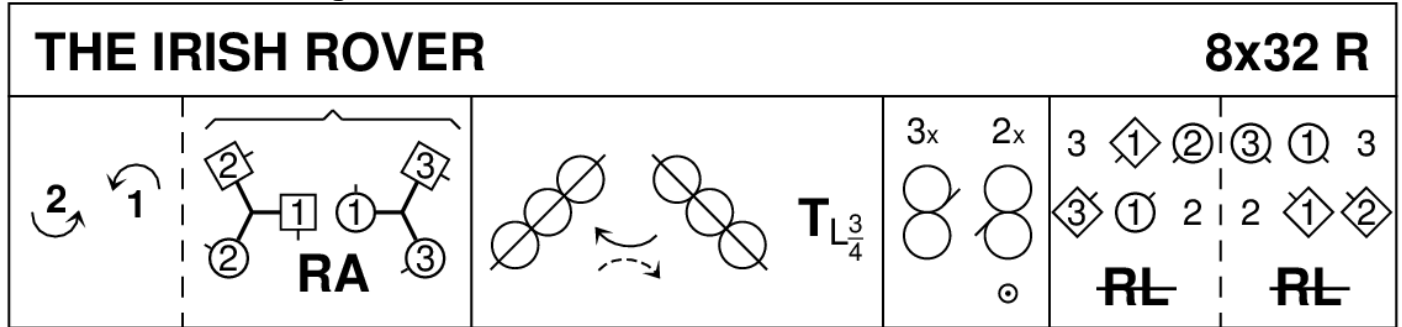

James B Cosh, 22 SCD & 1 other

3C/4C longwise set

**EXTRAS**

**17) EARLY SPRING (S3x32) 3C set Isabel Neves IB 10th Anniversary**

1-4 Men dance around partners (passing Right Shoulder) and back to place

5-8 All turn partners Right Hand, back to place

9-12 Ladies dance around partners (passing Left Shoulder) and back to place

13-16 All turn partners Left Hand, and stay in the middle facing up, holding left hand 17-24

1s+2s+3s dance Allemande (ending 3s; 2s; 1s)

25-32 3s+2s dance The Tourbillon (ending 2s; 3s; 1s)\*

"25-26: 3s & 2s turn partners 2H 1/2 way, 3M & 2L lead partners on 1 place clockwise to end 3s on Ladies side & 2s on Men's side

27-28: 3s set to 2s 29-30: 3s & 2s 1/2 turn partners 2H, 3L & 2M lead partners on 1 place to end 2s in 1st pl & 3s in 2nd pl

31-32: 2s+3s cross RH to own sides"

**Keith Rose's Crib Diagrams**

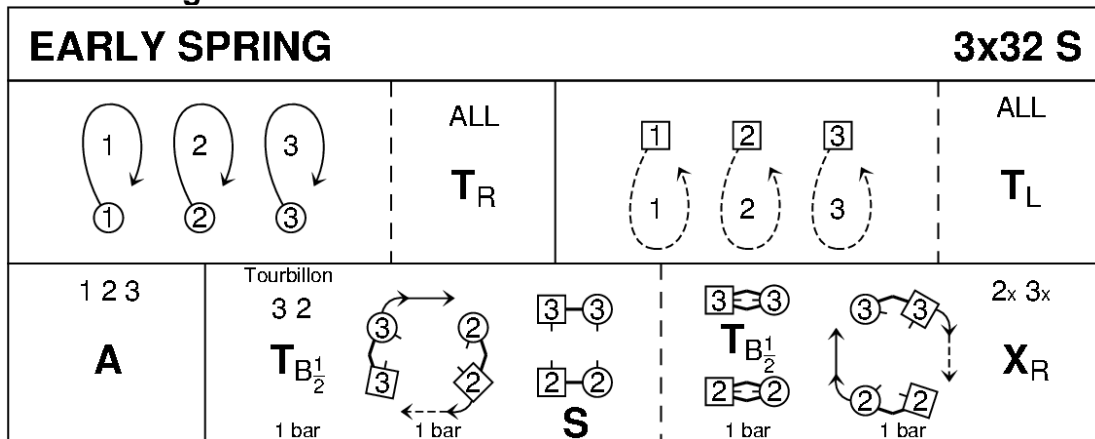

Isabel Neves, World Wide Weavings

3C/3C longwise set.



**18) REEL OF THE 51<sup>ST</sup> DIVISION** (R8x32) 3C (4C set) Atkinson RSCDS Bk 13









1- 8 1s set and cast below 3s, lead up to face 1st corners

9-16 1s set and turn 1st corners RH to balance in diagonal line, set and 1s turn LH to face 2nd corners

17-24 1s set and turn 2nd corners RH to Balance-in-Line, set and 1s turn LH to 2nd place own sides

25-32 2s+1s+3s circle 6H round and back.

**Keith Rose's Crib Diagrams**

THE REEL OF THE 51 <sup>st</sup> DIVISION			8x32 R
S  	S  T <sub>R</sub> B  T <sub>L</sub> <sup>1/4</sup>	  T <sub>R</sub>  T <sub>L</sub>	2 1 3 

Jimmy Atkinson & Peter Oliver, 1940, RSCDS Book 13.10

3C/4C longwise set.

MINICRIBS- Dance Cribs compiled by Charles Upton, Deeside Caledonian Society, and his successors

