

V December SCD Weekend in Portugal

Curia, Portugal

30 November 2018

Welcome Ball

Music: Keith Smith (fiddle) & Peter Shand (piano)

1. Kiss under the Stairs	8x32J	MMM2
2. Teachers' twin Birthday	3x32R	Isabel Monteiro for Joana and Roger
3. Gang the Same Gate	8x32S	Milton Levy RSCDS Book 36
4. Summer Wooing	8x32R	Alan MacPherson RSCDS Book 38
5. Best Set in the Hall	8x32J	Helen Greenwood RSCDS Book 46
6. The Library of Birmingham	4x40S	Kenneth J Reid RSCDS Book 49
7. Da Rain Dancin'	8x32R	Ron Wallace Whiteadder Collection

Interval

8. Sunshine and Sweetie's Jig	8x32J	Mervyn C Short RSCDS Book 48
9. Earlstoun Loch	5x32R	Hugh Foss Glendarroch SD Sheets
10. The Gentleman	8x32S	Kenneth J Reid RSCDS Book 49
11. The Laird of Milton's Daughter	8x32J	Lord Craigmyle RSCDS Book 22
12. Bratach Bana	8x32R	John Drewry Bon Accord Book
13. Fair Helen	4x32S	Isabel Monteiro
14. Rest and Be Thankful	8x32R	Grampian Collection

Extras

15. Mairi's Wedding	8x40R	James B. Cosh 22 SCDs
---------------------	-------	-----------------------



1) KISS UNDER THE STAIRS (J8x32) 3C (4C set) MMM 2

1- 8 1s set, cast down 1 place and circle 4H round to left with 3s

9-16 1s set, cast up and circle 4H round to left with 2s

17-24 1s lead down for 2 steps and back up to top, cast 1 place and turn RH to face down

25-32 1s lead down below 3s, cast up to 2nd place and 2s+1s+3s turn RH

Keith Rose's Crib Diagrams

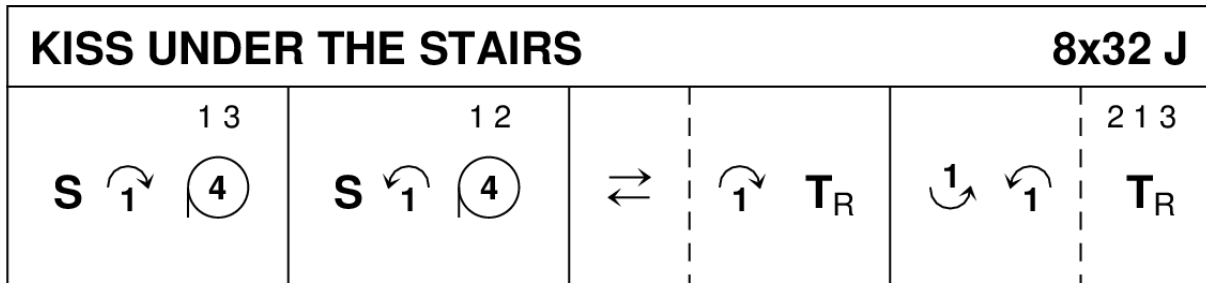

RSCDS MMM 2.15

3C/4C longwise set.

2) TEACHERS' TWIN BIRTHDAY (R3x32) 3C (4C set) Isabel Monteiro for Joana and Roger

1-8 1s set; long cast to second place (2s step up on 5-6); 1s RH turn into prom hold facing out/up 2nd man

9-16 1s in prom hold, RSh reel of 3 on men's side,

17-24 1s in prom hold LSh reel of 3 on Ladies side, start LSH with 2nd L

25-32 1s dance up the middle to top, cast one place behind 2nd couple, dance down the middle and turn 1+1/2 times 3rd couple with free hand, to finish 2,3,

3) GANG THE SAME GATE (S8x32) 3C (4C set) Milton Levy RSCDS Book 36

1- 8 1s cross RH and cast down to 3rd place, cross RH and cast up to 2nd place on own sides

9-16 1s set adv to partner and turn 1st corner 2H to face 2nd corner, 1s dance 1/2 diagonal reel of 4 ending M between top couple facing down and L between bottom couple facing up

17-24 1s set adv to partner and turn 4th corner (pstrn) 2H to face own 1st corner (pstrn), 1s dance 1/2 diagonal reel with 1st corners ending in 2nd place opposite sides

25-32 3s+1s+2s Set&Link for 3 twice. 213

Keith Rose's Crib Diagrams

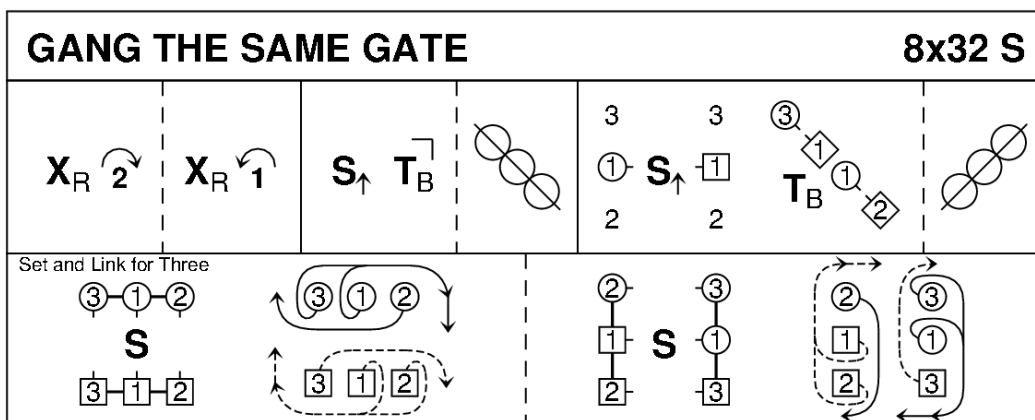

Milton Levy, RSCDS Book 36.4

3C/4C longwise set.



4) SUMMER WOONG (R8x32) 3C (4C set) Alan MacPherson RSCDS Book 38

1- 8 1s+2s circle 4H round to left, chase clockwise ½ way to end on opposite sides (2s in 1st place facing down and 1s in 2nd place facing up)
 9-16 2s+1s+3s dance RSh reels of 3 on sides
 17-24 1s followed by 2s lead down for 3, 2s divide and follow 1s back to top, 1s+2s retain RH and Men pass in front of Ladies as they turn under right arm
 25-32 1s+2s dance Poussette. 213

Keith Rose's Crib Diagrams

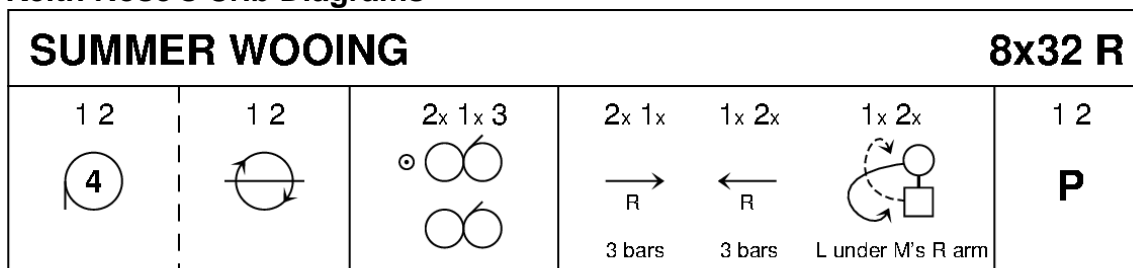

Alan Macpherson, RSCDS Book 38.6

3C/4C longwise set.

5) BEST SET IN THE HALL (J8x32) 3C (4C set) Helen Greenwood RSCDS Book 46

1- 8 1s set and 1L followed by partner casts below 3s. 1L Crosses&Casts up to face her 1st corner while 1M dances up the middle to face 1st corner
 9-12 1s set to 1st corners and dance RSh round each other into 3rd corner (pstn) while 1st corners dance in and turn right about to face their original position
 13-16 1s+1st corner person set and 1st corner persons dance RSh round each other into diagonal opposite corners while 1s dance in and pivot to right to face 2nd corners
 17-24 1s repeat bars 9-16 with 2nd corners and end passing RSh to 2nd place opposite sides.
 (3)(1)(2)
 25-32 2s+1s+3s chase clockwise ½ way and turn partners RH

Keith Rose's Crib Diagrams

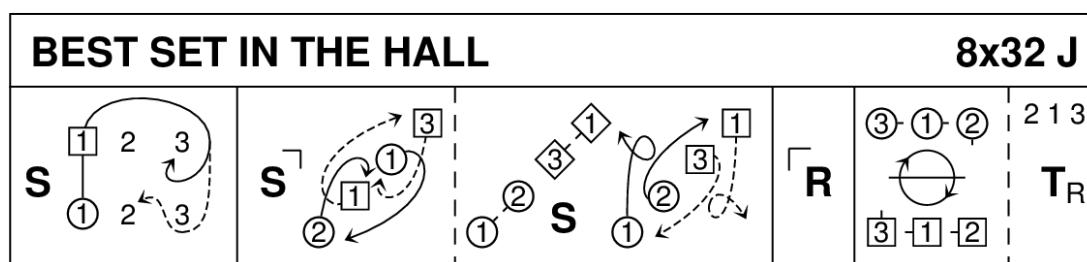

Helen Greenwood, 2003, RSCDS Book 46.7

3C/4C longwise set.

6) THE LIBRARY OF BIRMINGHAM (S4x40) 4C set Kenneth J Reid RSCDS Book 49

1- 8 1s+2s also 3s+4s dance Rose Progression:-
 ' 1- 2 1M+2L set as 1L+2M change places RH
 ' 3- 4 1M+2L ½ turn 2H as 1L and 2M dance into partner's place
 ' 5- 6 1M+2L cast into each other's place as 1L+2M ½ turn 2H
 ' 7- 8 1M and 2L dance into 2nd/1st places own side as 1L and 2M cast to right to new places (3s+4s dance similarly)
 9-16 All dance clockwise ½ way round set, all set. All ½ turn partner RH into Allemande hold



17-24 3s+4s also 1s+2s dance 6 bars of Allemande. All ½ turn LH to opposite sides. (Men face up, Ladies down)

25-32 All dance anticlockwise ½ way round set. 1s+2s also 3s+4s circle 4H round to Right. 1234

33-36 All 4 couples Set&Link with middle dancers linking 2 places; end dancers linking 1 place as follows:-

' 33-34 All set

' 35-36 1M dances down to 2nd place, 2M to 4th place, 3M casts up to 1st place, 4M to 3rd place while 1L casts to 2nd place, 2L to 4th place, 3L dances up to 1st place, 4L to 3rd place. 3142

37-40 3s+1s also 4s+2s circle 4H round to Left

Keith Rose's Crib Diagrams

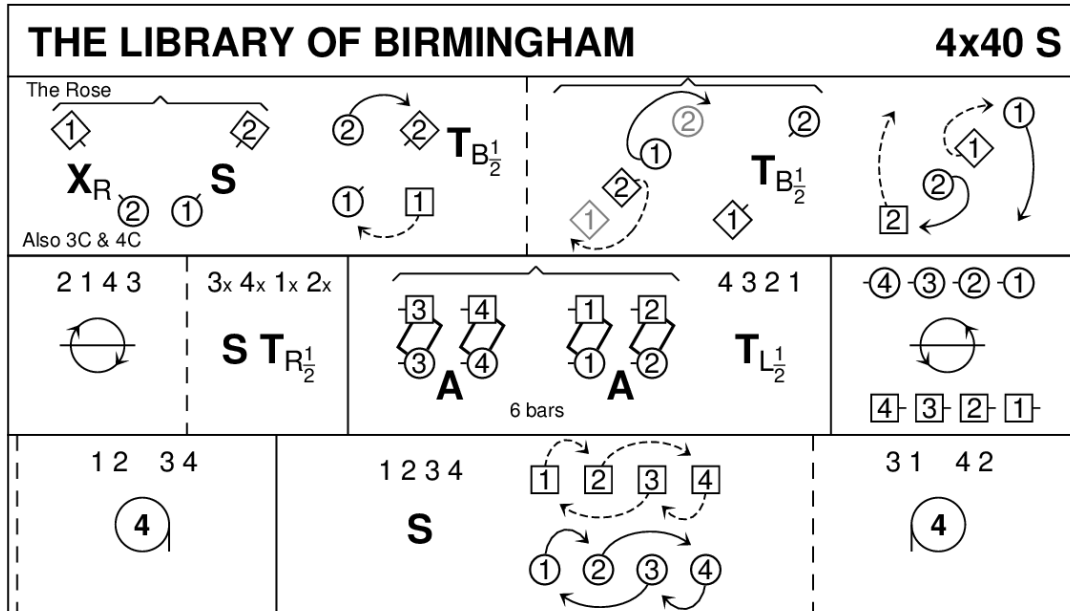

Kenneth J Reid, 2013, RSCDS Book 49.9

4C/4C longwise set.

7) DA RAIN DANCIN' (R8x32) 3C (4C set) Ron Wallace Whiteadder Collection

1- 8 1s dance down below 3s, cast up round 3s to 2nd place own side, 2s+1s+3s set and cross RH

9-16 1s dance up round 2s and cast down to 2nd place opposite sides, 2s+1s+3s set, 1s turn LH to face 1st corners while 2s and 3s cross LH

17-24 1s dance 'Hello-Goodbye' setting with 1st corners and ¾ turn RH to face 2nd corners, 1s dance 'Hello-Goodbye' setting to 2nd corners and ¾ turn RH to end 2nd place own side

25-32 2s+1s+3s circle 6H round and back

Keith Rose's Crib Diagrams

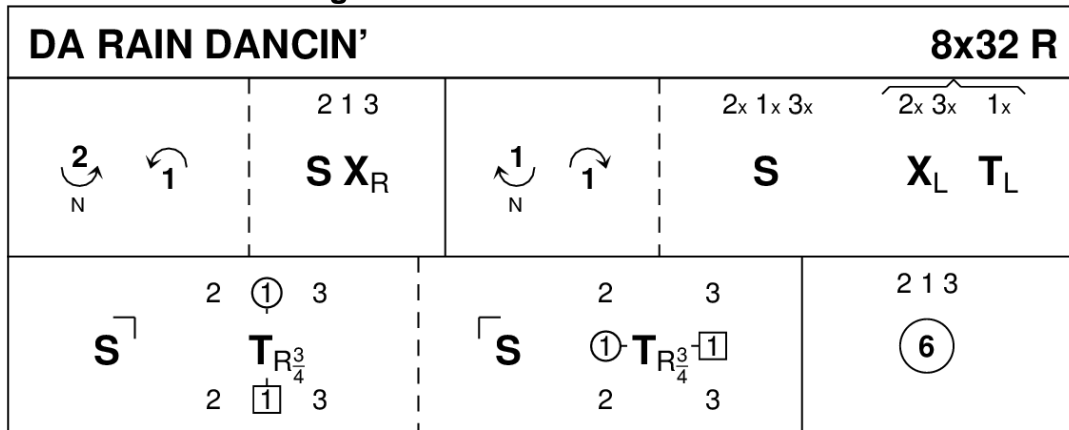

Ron Wallace, 1991, Whiteadder Collection

3C/4C longwise set.



10) THE GENTLEMAN (S8x32) 3C (4C set) Roz Scott Huxley RSCDS Book 35

1- 8 1s turn 2H and remain in middle facing each other as 2s step up, 1s+2s set (1s advancing and pass LSh to face opposite partner) and dance ½ reel of 4 across with 2s with 1s ending reel giving LH to face down on own side between 2s

9-16 1s dance down to end between 3s and face each other, 1s+3s set (1s advancing and pass LSh to face opposite partner) and ½ reel of 4 across with 3s 1s end giving LH to face up on own side between 3s

17-24 1s lead up to top, cross over and cast to 2nd place and ½ reels of 3 across (L with 2s and M with 3s)

25-32 2s+1s dance Diamond Poussette. 213

Keith Rose's Crib Diagrams

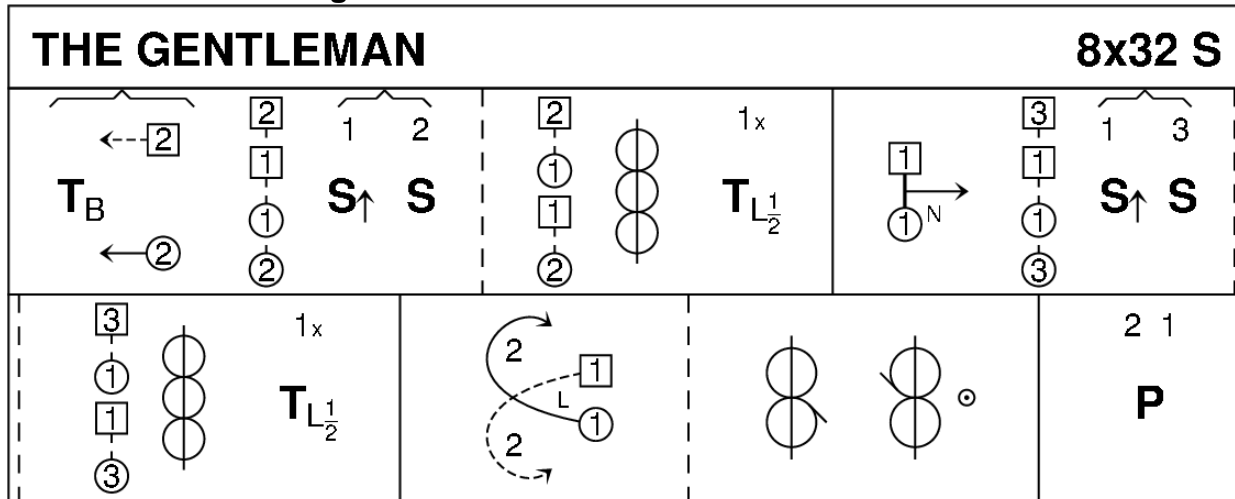

Roz Scott Huxley, 1986, RSCDS Book 35.5

3C/4C longwise set.

11) THE LAIRD OF MILTON'S DAUGHTER (J8x32) 3C (4C set) Lord Craigmyle RSCDS Book 22

1- 8 1s set, cross RH, cast 1 place and turn LH to face 1st corners

9-24 1s dance Corner Chain with 1st and 2nd corners:-

' 1s change places RH with 1st corners, 1st corners turn LH in centre and return to places giving RH to 1s who turn LH in centre to face 2nd corners

' 1s change places RH with 2nd corners, 2nd corners turn LH in centre and return to places giving RH to 1s and 1s end with a ½ turn LH to 2nd place own sides

25-32 2s+1s+3s circle 6H round and back

Keith Rose's Crib Diagrams

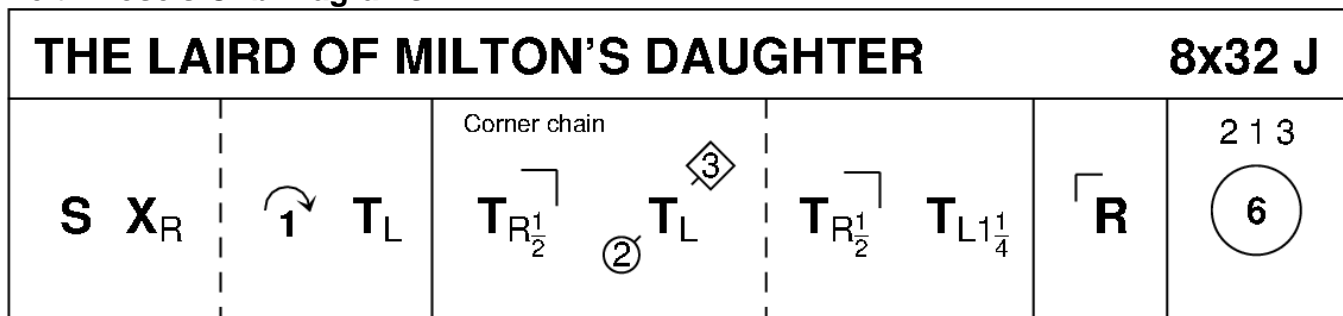

Lord Craigmyle, RSCDS Book 22.10

3C/4C longwise set.



12) BRATACH BANA ((R8x32) 3C (4C set) John Drewry Bon Accord Book

1- 8 1s turn RH and cast 1 place, 1s dance LSh round 1st corners to 2nd place opposite side facing 2nd corners

9-16 1s dance ½ Reel of 3 on the sides and dance ½ Reel of 3 across (1M with 3s at top, 1L with the 2s)

17-24 1s turn LH, turn 3rd corners RH (1st corner person) and pass RSh to turn 4th corner RH ending in 2nd place own side in prom hold with 4th corner

25-32 1s+4th corners Prom diagonal across (pass RSh) to diagonal opposite corner and ½ turn to end 1s in 2nd place opposite side, 1s dance ½ diagonal R&L (M up, L down) to end in 2nd place

Keith Rose's Crib Diagrams

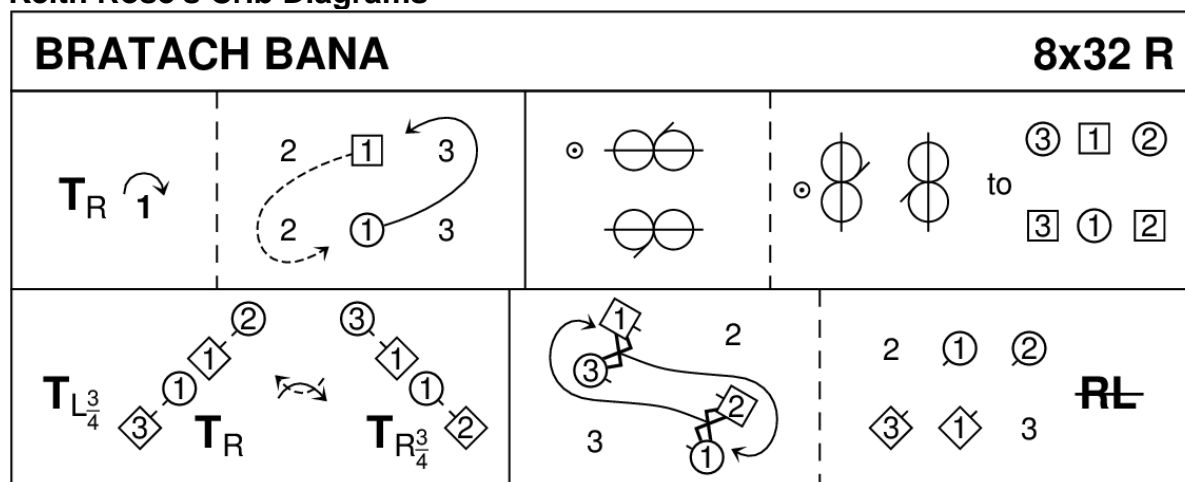

John Drewry, Bon Accord Book

3C/4C longwise set.

13) FAIR HELEN (S4x32) Sq.Set Isabel Monteiro

1-4 1s+3s RA back to places; while 2s+4s chase (ladies followed by partners) anticlockwise ½ way

5-8 4s+2s LA; while 1s+3s chase clockwise ½ way (all finish: 3,4,1,2)

9-16 3s+1s Bourrel modified:

While men dance anticlockwise to their right behind standing couples, 1L and 3L set advancing towards each other up/down; turn BH and twirl, set to partner and turn partner 1+¼ RH

17-24 4s+2s Repeat the Bourrel (all finish in original positions: 1,2,3,4, with ladies facing out)

25-28 Schiehalion Reel (only 4 bars)

29-32 All set to partner and turn BH

Repeat from new positions

14) REST AND BE THANKFUL (R8x32) 3C (4C set) Grampian Collection

1- 8 1s cross RH and cast 1 place, cross LH and cast (Lady up and Man down) to meet 1st corners in prom hold

9-16 1s+1st corner dance ½ way round behind 2nd corner to 3rd corner while 2nd corners Adv&Ret, 1s leave 1st corners and turn LH to meet 2nd corners in prom hold (1st corners now in diagonal opposite place)

17-24 1s dance with 2nd corner person ½ way round to 4th corner while 1st corners Adv&Ret, 1s leave 2nd corners and turn LH to face 1st corner (pstrn)

25-32 1s dance ½ diagonal Reel of 4 with 1st corners and ½ Reel with 2nd corners to end on own sides 2nd place



Keith Rose's Crib Diagrams

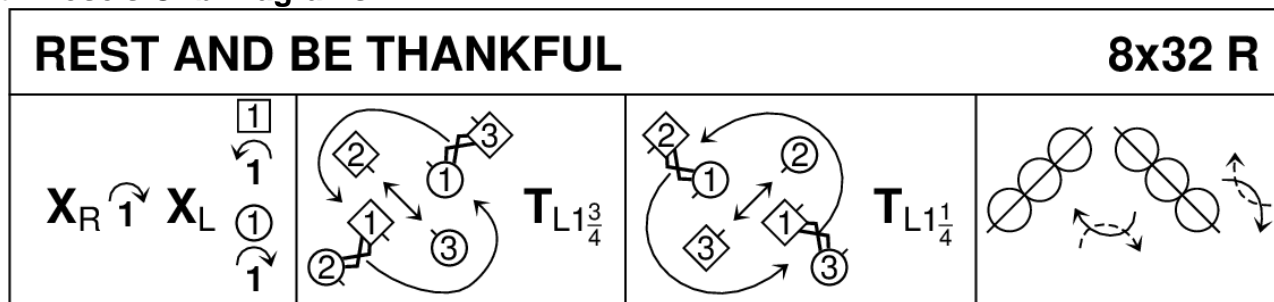

Jack McConachie, Grampian Collection

3C/4C longwise set

EXTRAS:

15) MAIRI'S WEDDING (R8x40) 3C (4C set) James B. Cosh 22 SCDs

1- 8 1s turn RH and cast to 2nd place, 1s turn LH to face 1st corners

9-16 1s dance ½ diagonal reel of 4 with 1st corners, 1s dance ½ diagonal reel with 2nd corners

17-24 1s dance ½ diagonal reel with 3rd corner (pstns), ½ diagonal reel with 4th corner (pstns)

25-32 1s dance reel of 3 across (Lady with 2s, Man with 3s - LSh to 1st corner)

33-40 2s+1s+3s circle 6H round and back. 213

Keith Rose's Crib Diagrams

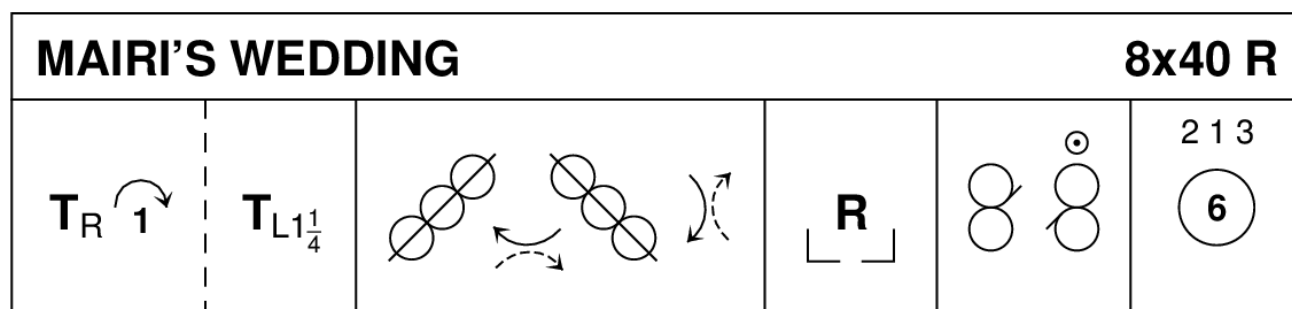

James Cosh, 1959, 22 SCD & 1 other

3C/4C longwise set

MINICRIBS- Dance Cribs compiled by Charles Upton, Deeside Caledonian Society, and his successors

